

BASIC USER GUIDE

Outlast Extreme 1320i-L Settings



TABLE OF CONTENTS

Introduction	1	Cerbo-S GX	11
VictronConnect	2	Dashboard	11
Main Tabs	2	Connecting to the Cerbo	11
Pairing Procedure	3	External Wi-Fi	11
Reset Lost Password	3	Internal Wi-Fi	11
SmartSolar Controller	4	VRM Set-up and Linking System	12
Settings	4	Menu	12
Controller Status Lights	4	VRM Portal	13
SmartShunt	5	Remote Console	14
Overview	5	Understanding the Remote Console	14
Recommended Settings	6	Remote Console Navigation	14
Batteries	7	Settings	14
Battery Heat Overview	7	Understanding Settings	15-16
When to Turn On Battery Heat	7	SmartShunt on Remote Console	17
MultiPlus-II Inverter/Charger	8-9	SmartSolar Controller on Remote Console	17
Cerbo-S and GX Touch	10	FAQs	
		Cerbo GX FAQs	18-19
		General FAQs	19
		Tech Tips	20
		Batteries: How Batteries are Rated	20
		Appendix: Charts	21
		At Rest Voltage vs SOC	21
		Appendix: Links	22
		Notes	23

INTRODUCTION

Dear Outlast Extreme Owner,

Congratulations and thank you for your purchase of your new Keystone Outlast Extreme 1320i-L System. We know this will help you on your journey with your new Fifth Wheel.

To help get you started, we encourage you to take a few minutes and review the Owner's Manual thoroughly. There are many components, system settings and equipment unique to a recreational vehicle. Getting an understanding of how they function will be important to safe operation, getting the most from your system, and your overall enjoyment.

If you have any questions, please contact your selling dealer or the Keystone Customer Service Group at 866-425-4369. Additional information and resources about your system can be found at <https://www.keystonerv.com> or <https://www.fsi-solutions.com/owners-manuals>.

The Future Solutions Team thanks you again for purchasing a Keystone product. Enjoy camping with your own power!

- The Future Solutions Team

YOUR OUTLAST EXTREME 1320i-L INCLUDES:

(2) 30A Solar Roof Ports



(1320W) Future Solutions Solar Array



(2) 50A Victron Smart MPPT Controller



Victron Multi-Plus II 2x120V
Inverter/Charger



(2) CS3 Solar Cable Splitters



Victron SmartShunt Battery Monitor



GX Touch
(Optional display for Cerbo GX
and Cerbo-S GX)



(540Ah) Dragonfly®
Lithium Ion Batteries



Victron Cerbo-S GX



In Partnership With Future Solutions.

This manual is based on the latest information available at the time of publication. Due to continuous product development and improvements, Future Solutions reserves the right to make changes in product specifications and components without prior notice. The most recent version of the owner's manual can be found on our website at www.fsi-solutions.com/owners-manuals or www.keystonerv.com under the Customer Service heading.

VICTRONCONNECT APP



Your system includes components from Victron’s “Smart” energy line with Bluetooth connectivity in place of a physical remote display. This includes the SmartShunt, MPPT SmartSolar Controllers, and the Cerbo-S GX. The SmartShunt is monitoring your battery state and tracking how much power is flowing to or from the battery bank, giving you valuable information regarding your State-of-Charge (SOC).

The MPPT SmartSolar Controller is regulating the power produced by the solar panels to charge the batteries. Both of these devices have stand-alone Bluetooth connectivity and can be viewed individually by using the VictronConnect App on a smart phone or tablet. These devices also report to the Cerbo-S GX, which acts as a connectivity and monitoring hub for your system. This section contains details for each of these devices.

Victron Connect

Opening the VictronConnect app will cause it to look for ANY Victron items with a Bluetooth signal within range. Specific items can be identified by the Icon, as well as the device “nick-name”. The default nickname is the device serial number. **Serial numbers** for your devices, as well as information needed to connect to your Cerbo-S GX are found on the sticker located on the cover of your component plate, as well as on the side of your battery.

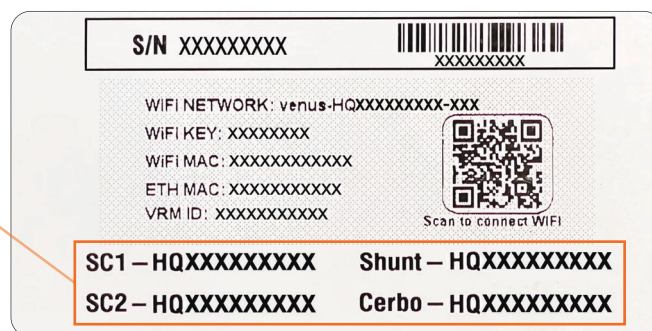

The first time you connect to any device, you will have to enter the default password (000000). You can change the password when prompted if you choose, or you can also change the password in settings at a later time.

If you have lost or forgotten your password, they can be reset through the app, but this does require a PUK number (a special code) that is on the serial number sticker of the device. This number is required to ensure that you have physical possession of the device before clearing a password.

Each of your Bluetooth devices will have three tabs across the top: *Status, History, and Trends*.

Main Tabs

STATUS: Shows live-time information regarding battery conditions.

HISTORY: The device stores historical values in non-volatile memory. This means this data will not be lost when the power to the device has been interrupted. These can be used at a later date to evaluate usage patterns and battery health.

TRENDS: This section of VictronConnect enables data-logging, but only while the app is connected and communicating with the SmartShunt. It will simultaneously log two of the following parameters: Voltage, Current, Power consumed Ah, or State of Charge.

Once connected, you can change the device nick name, and change or add a password. To do this, click the settings (⚙️) in the top right corner. Once in main settings menu, select the menu (⋮) in the top right corner, and choose “Product Info”. This is where you can change the name of the device, check for updated firmware, and change the password to log onto the device.

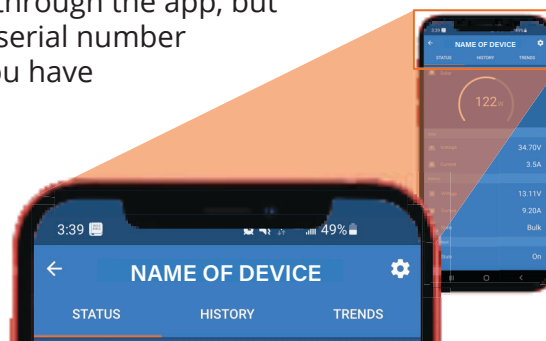

VICTRONCONNECT APP CONTINUED

Pairing Procedure

Default pincode is 000000.

After connecting, the pincode can be changed by going into "Settings" (⚙️), select "Menu" (⋮), "Product Info", and here you can change the product name and pincode.

Apple Store



Google Play Store

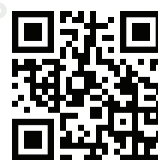

User Manual



Reset Lost Password

You will need to "forget" the device from your device list. If you are not sure how to do this, a link will be displayed during the process that you can follow to learn how.

- 1) Locate and write down the PUK number from the device you are trying to reset.
 - a. On the SmartShunt and SmartSolar Controller: this is on a sticker on the side of the component. Reference below for label locations.
- 2) Select the Menu (⋮) to the right of the signal strength meter.
- 3) Choose "Reset PIN code".
- 4) If you have not removed the device from your Bluetooth list yet, follow the link at the bottom of the warning message, complete the removal, and start at *step 1* again. Otherwise, proceed to *step 5*.
- 5) Enter PUK number and click "OK".



SMARTSOLAR CONTROLLER



This system is utilizing the SmartSolar MPPT 100|50 Solar Controllers. A Solar Controller charges a lower nominal-voltage battery from a higher nominal voltage PV array. The Solar Controller will charge the battery with a current up to its rated output. The SmartSolar MPPT 100|50 Solar Controller has a maximum of 50 amps output. Selecting the SmartSolar Controller in VictronConnect will open the main screen.

1) Wattage Readout (Solar): This shows how many watts are being processed through this SmartSolar Controller.

2) Solar (Voltage and Current): This shows the voltage of your panels and how much current is coming from the panel array.

3) Battery (Voltage, Current, and State): This shows the battery bank voltage, charging current and the current charging state of the SmartSolar Controller.



Settings

In the settings menu (⚙️), under the “Battery settings” section, you have the option to reduce the max charge current, disable the Charger, or change the battery type. It is recommended that the battery type be set to “rotary switch” and it should read “Position 7” in the info box.

NOTE: Battery type settings on VictronConnect App over-rides the rotary switch settings of charge Controller.

Controller Status Lights

The charging state of the Controller can also be observed using the LED lights on the physical Solar Controller.

Light Indicator Key:

- 🔄 Blinking
- On
- Off

	LEDs	BULK	ABSORPTION	FLOAT
REGULAR OPERATION	Not charging (*1)	🔄	○	○
	Bulk (*2)	●	○	○
	Absorption (*2)	○	●	○
	Automatic equalization (*2)	○	●	●
	Float (*2)	○	○	●
FAULT SITUATION	Charger temperature too high	○	○	🔄
	Charger over-current	🔄	○	🔄
	Charger or panel over-voltage	○	🔄	🔄
	Internal error (*3)	🔄	🔄	○

NOTE *1) The bulk LED will blink briefly every 3 seconds when the system is powered but this is insufficient power to start charging.

NOTE *2) The LED(s) might blink every 4 seconds indicating that the Charger is receiving data from another device, this can be:

- A GX Device (e.g. Color Control with a Multi in ESS mode)
- A VE.Smart network link via Bluetooth (with other MPPT Chargers and/or a BMV or Smart Battery Sense)

NOTE *3) e.g. Calibration and/or settings data lost, current sensor issue.

SMARTSHUNT

The SmartShunt is a very valuable piece of equipment in your system. This is the component that is responsible for helping you keep track of just how much energy is left in your battery bank at any given time. This component simply measures battery voltage and current. With those measurements, and the info provided to it through the settings menu, SOC (State-of-Charge), and Time Remaining are calculated.



Overview

***1) State of charge:** Percentage of energy in battery bank. This is a calculated number based on settings and should be periodically checked against the Voltage to SOC chart. See *At Rest Voltage vs SOC Chart* on pg 21.

2) Voltage: This is the battery bank voltage level.

3) Current: A negative number indicates current (A) flowing from the battery bank; a positive number indicates current (A) flowing to the battery bank.

4) Power: This is the NET Power (Watts) flowing to or from the battery bank. A negative number indicates power (W) flowing from; a positive number indicates power (W) flowing to the battery bank.

***5) Consumed Ah:** The SmartShunt keeps track of the Amp-hours removed from the battery (compensated for the efficiency). Example: If a 10-amp load is ran for 4 hours, the read out will show -40.0 Ah (-10amps x 4 hour = -40.0).

***6) Time remaining:** This is an estimate of how long the battery bank can support the present load under the present conditions. If the loads being ran fluctuate heavily, it is best not to rely on this reading too much as it is a momentary readout and should be used as a guideline only.

Selecting the SmartShunt will open to the main info screen.

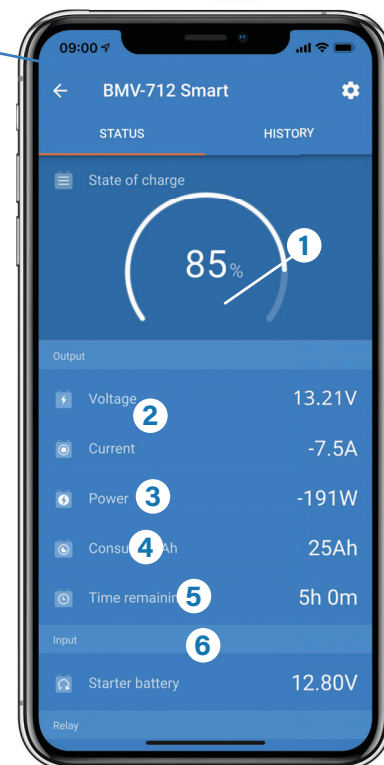

***NOTE:** If “- -” are shown, this means that the shunt is in an unsynchronized state. This can occur when the system has been left unpowered for a period of time and is powered up again. See paragraph 5.3 “Synchronizing the SmartShunt” in the SmartShunt Manual.

NOTE: **Current** is the NET current flow (adding all charging sources and subtracting all loads) flowing to or from the battery bank.

SMARTSHUNT CONTINUED

Recommended Settings

The settings on the SmartShunt need to be accurate in order to provide proper data regarding the Consumed Amp-hours, State of Charge, and Time Remaining readouts. If you find your readings are off, review your settings to ensure they are correct. *All settings are recommended by Dragonfly Energy.*

Battery capacity: This should be set to the size of your battery bank. 1320i-L with GC3 Batteries should be [set to 540Ah](#)

Charged voltage: This is the battery voltage that MUST be met before the SOC is reset to 100%.

DFE Recommended Setting – 14.1V

Discharge floor: This setting is used in the “time to go” calculation.

DFE Recommended Setting – 0%

Tail current: This setting is used to determine when SOC is reset to 100%.

DFE Recommended Setting – 3.50%

Charge detection time: This setting is the amount of time that “Charged Voltage” and “Tail Current” must be met before the SOC is reset.

DFE Recommended Setting – 3m

Peukert exponent: This setting is used in calculations of SOC.

DFE Recommended Setting – 1.05

Charge efficiency factor: This setting compensates for the amp-hours lost to heat during charging.

DFE Recommended Setting – 99%

Current threshold: This setting controls the smallest value of current that the system will recognize.

DFE Recommended Setting – 0.10A

Time-to-go averaging period: This is the time period that is averaged to get the “Time-to-go” value.

DFE Recommended Setting – 3m

Battery starts synchronized: This selection will cause the SOC to reset to 100% anytime the Shunt is powered up after having been disconnected.

DFE Recommended Setting – Disabled

State-of-Charge: With this setting, you can manually set the state of charge value. This setting is only active after the SmartShunt has, at least once, been synchronized (automatically or manually). For more information on this, see *At Rest Voltage vs SOC Chart* in the appendix on pg 21.

DFE Recommended Setting – N/A

Synchronize SOC to 100%: This option can be used to manually synchronize the SmartShunt.

DFE Recommended Setting – N/A

Zero current calibration: This option can be used to calibrate the zero reading if the battery monitor reads a non-zero current even when there is no load, and the battery is not being charged.

DFE Recommended Setting – N/A

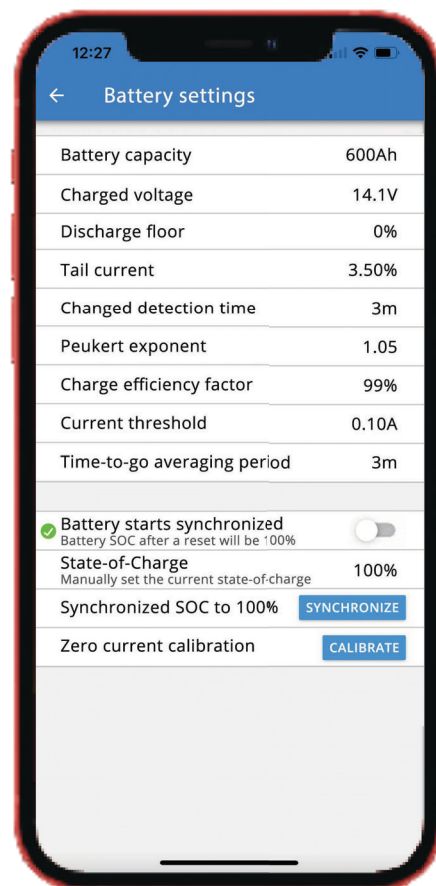

BATTERIES

Battery Heat Overview

Your batteries are equipped with built in battery heaters to ensure cold climate does not stop your batteries from charging. The heaters are enabled or disabled by a lighted switch inside of the coach or on the iN-Command Display Commander's Battery Heat trigger. When the switch is turned on, the heaters will automatically activate when the internal temperature of the battery drops below approximately 35°F (1.6°C) and will automatically shut off when the internal temperature exceeds approximately 45°F (7.2°C).

NOTE: If the battery has been cold soaked (exposed to below freezing temperatures for a long period of time without the heater enabled), it will take 2-4 hours for the internal components of the battery to heat up enough for the battery to accept a charge.

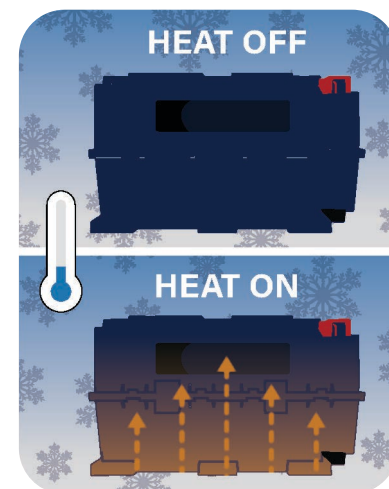

The heaters draw 1.8 amps (per battery) of power and typically run on a 30% duty cycle. This means at 0°F, the heaters will be on 30% of the time, and off 70% of the time. That means if it is cold, we can expect 0.6 Ah of energy (per battery) to be used to keep the batteries at proper charging temperatures.

When to Turn On Battery Heat

If you are using the coach and the temperature is below freezing, you will want to turn on the battery heat to ensure you are able to take advantage of charging from your solar set up. The heat can either be turned on just prior to charging, or left on while the coach is in use. Both options have pro's and con's and are based on personal preference and use case.

While leaving the heat on while the coach is in use, you could be using energy to keep the batteries warm when it is not necessary (remember: it is only really necessary when trying to charge) it also ensures that if you are charging from solar, the batteries are always able to accept power when it is available.

Only enabling the heat prior to charging will conserve more battery power, but it can also take an extended period of time for the batteries to warm up to be able to charge if they are cold soaked. In the end, the important thing to remember is if the temperature is at or below 35°F, you will need to activate the battery heat in order to charge the batteries.

NOTE: DRAGONFLY DOES NOT RECOMMEND BATTERY HEATER BE ACTIVE WHEN STORING THE BATTERY.

MULTIPLUS-II 2X120V INVERTER/CHARGER

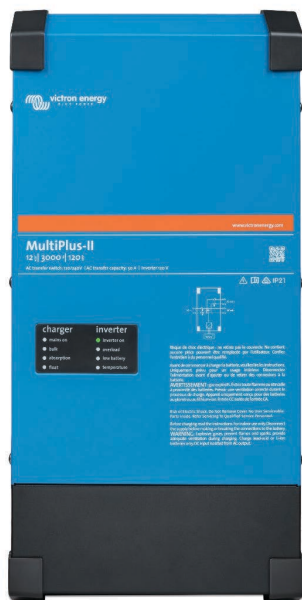

120/240V input and output, or 120V input and output (always 120V output when in inverter mode)

The AC input can be supplied from a split phase 120/240V source, or single phase 120V source. When an AC source is available, the MultiPlus will feed through the AC to its output. The output will therefore mirror the AC input. The inverter/charger connects to the neutral and the preferred input line (L1). Power needed to charge the batteries will therefore be drawn from L1. The MultiPlus switches to inverter operation when no AC source is available. The inverter output is 120V single phase. In invert mode, the MultiPlus connects both output lines (L1 and L2) together to provide 120VAC to loads on either line. Any 240V loads will therefore be supplied only when the MultiPlus is supplied by a split phase AC source. This prevents heavy loads such as water heaters or 240V air conditioners from discharging the battery

PowerControl and PowerAssist - Boosting the capacity of the grid or a generator

A maximum grid or generator current can be set. The MultiPlus will then take account of other AC loads and use whatever is extra for battery charging, thus preventing the generator or grid from being overloaded (PowerControl function). PowerAssist takes the principle of PowerControl to a further dimension. Where peak power is so often required only for a limited period, the MultiPlus-II will compensate insufficient generator, shore or grid power with power from the battery. When the load reduces, the spare power is used to recharge the battery (available on L1 input only).

Two AC Outputs

The main output has no break functionality. The MultiPlus takes over the supply to the connected 120V loads in the event of a grid failure or when shore/generator power is disconnected. The transfer time of the L1 output is less than 18 milliseconds so that computers and other electronic equipment will continue to operate without disruption. The transfer time of the L2 output is longer: approximately 40 milliseconds. The second (auxiliary) output is live only when AC is available on the input of the MultiPlus. Loads that should not discharge the battery can be connected to this output.

MULTIPLUS-II 2X120V INVERTER/CHARGER

CONTINUED

Remote configuring and monitoring

Install a Cerbo GX or other GX product to connect to the internet. Operational data can be stored and displayed on our VRM (Victron Remote Management) website, free of charge. When connected to the internet, systems can be accessed remotely, and settings can be changed.

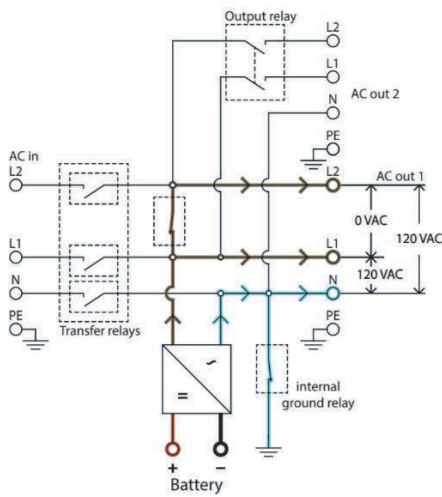

Power flow: inverter mode

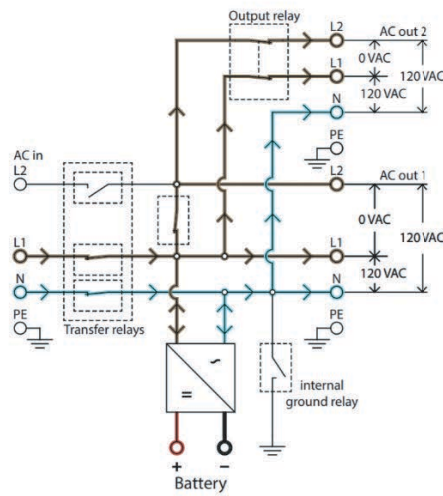

Power flow, 120VAC-input

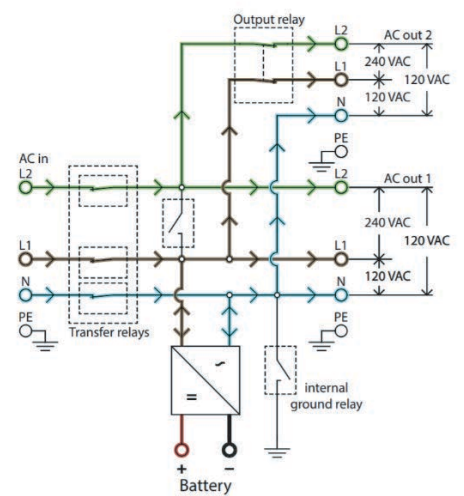

Power flow, split phase input

CERBO-S GX AND GX TOUCH

GX Touch: Display Accessory

The GX Touch 50 is a display accessory for the Cerbo-S GX. The five inch touch screen display gives an instant overview of your system and allows you to adjust settings. Simply connect the display to the Cerbo-S GX with just one cable. Both GX Touch displays have a waterproof design, a top-mountable setup and are simple to install. The supplied (from serial number HQ2242) protection cover prevents damage from UV light during prolonged exposure to the sun.



Cerbo-S GX

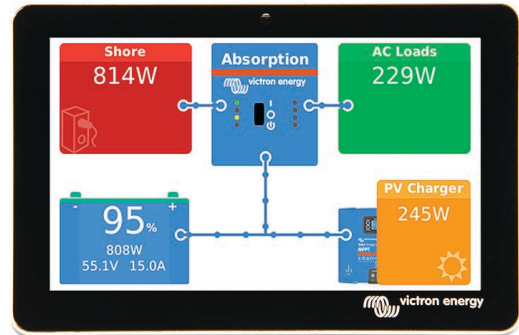

GX Touch (optional display for Cerbo GX and Cerbo-S GX)

CERBO-S GX

Dashboard

This all-new communication center allows you to always have control over your system from wherever you are. All of your Victron equipment is reporting to the Cerbo-S GX which then displays the data on an intuitive interface that is easy to understand and operate. The Cerbo-S GX has built in Bluetooth, built in Wi-Fi access point, as well as the ability to connect to a local LAN or Wi-Fi Network.

Connecting to the Cerbo

The Bluetooth option on the Cerbo-S GX has limited functionality. It is intended to be used to assist with initial connection and networking configuration. Review the section for VictronConnect (pg 2) for instructions on how to connect a device with Bluetooth. Once opened, you will be able to set the PIN, name your device, and select external Wi-Fi networks.

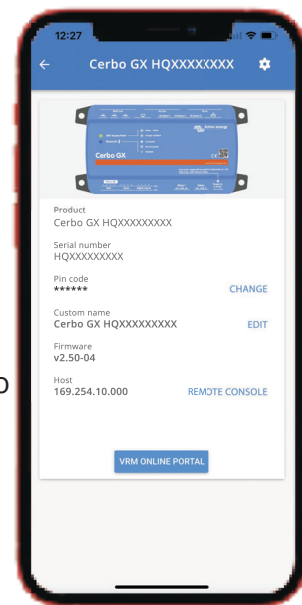

External Wi-Fi

If you have a Wi-Fi signal you would like to use to access the Cerbo-S GX (possibly through a hot-spot or other mobile network) you can log the Cerbo-S GX onto the network through the Bluetooth connection.

- 1) From the main screen, select the Settings (⚙️).
- 2) Choose your desired network from the list of available networks.
- 3) Enter your network password.

NOTE: This Wi-Fi access point does not have an internet connection and is only used to view the remote console when you are near the unit. You can access this network in two ways.

Internal Wi-Fi

If you do not have a Wi-Fi signal, you can still access the remote console by accessing the internal Wi-Fi access point of the Cerbo-S GX.

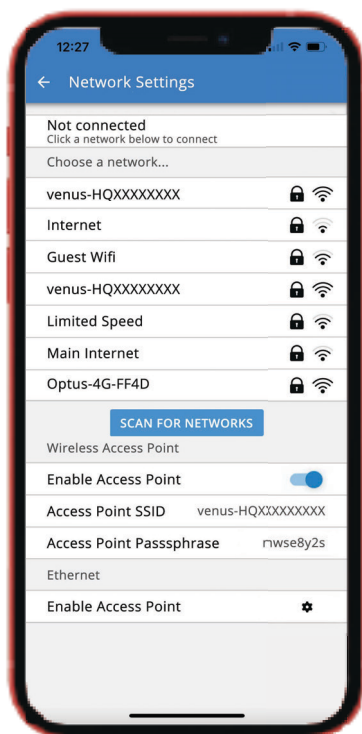

- 1) Connecting automatically via the QR code:
 - a. Locate the QR code sticker on the component plate of your system.
 - b. Scan the QR code using your phone's camera function or a QR code scanning app.
 - c. If supported by your phone, this will prompt you to connect to the Wi-Fi access point.
 - d. Once connected, open VictronConnect.
 - e. Select the GX device from the list then open the Remote Console.
- 2) Manually Connecting:
 - a. Stand as close as possible to the Cerbo-S GX (within a few meters).
 - b. Go to the Wi-Fi settings on your phone or tablet.
 - c. After searching for local networks, the Cerbo-S GX will show up in the list as something like "Venus-HQ1940DEFR4-3b6".
 - d. Connect to Wi-Fi using the Wi-Fi key printed on the sticker on your component plate.
 - e. Open VictronConnect, it will start automatically scanning the Wi-Fi network.
 - f. Once found, select the GX device from the list.
 - g. Open the Remote Console. Read more about this on pg 14.

WIFI NETWORK: venus-HQXXXXXXXX-xxx
 WIFI KEY: xxxxxxxx
 WIFI MAC: xxxxxxxxxxxx
 ETH MAC: xxxxxxxxxxxx
 VRM ID: xxxxxxxxxxxx



Scan to connect WiFi

CERBO-S GX CONTINUED

VRM Set-up and Linking System

NOTE: CERBO-S GX NEEDS TO BE POWERED UP AND BE LINKED TO A WI-FI NETWORK WITH INTERNET ACCESS.

1) Go to <http://www.victronenergy.com>, click on the 'Login' tab and select 'VRM'. Select the 'Register for Free' icon below the log in screen. Here, you will need to provide your name, email address, phone number, city, country, and select a new password.

2) You should receive a verification email with a link to your new account. Next time you go to the VRM homepage, you will simply have to enter your email and your password. Clicking on the link takes you to a page to

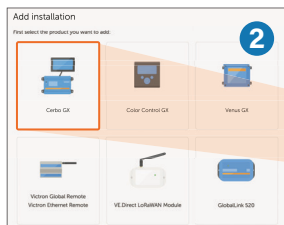

add your installation. Click 'Cerbo-S GX'.

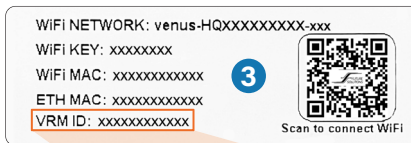

3) It will ask for an Installation ID and an Installation name. The Installation ID can be found on the serial number sticker of your 1320i-L system. This should be located on the cover of the plate. It can also be found on a sticker on the bottom of the Cerbo-S GX. The VRM ID can also be found using the Remote Console. For more on that, see Remote Console section starting on pg 14.

4) Enter the alpha-numeric code for the VRM Portal ID and you can choose to name the installation anything you want (example: Jones RV).

Menu

Once your Cerbo is linked to your new VRM account, you will see an overview of your system as the main backdrop, with a menu of options on the left.

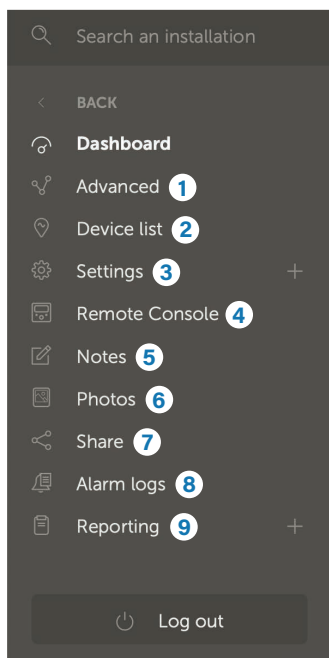

- 1) **Advanced:** Opens the data tracking portion of the portal. Under 'widgets' in the top right corner, you can find all of the different options of data available for each of your devices.
- 2) **Device List:** This opens a screen that shows each of your connected components. Clicking on a component shows you the serial number, firmware version, and much more.
- 3) **Settings:** Options here include adding other users to the account, changing the name of the installation, and unlinking an installation.
- 4) **Remote Console:** This allows you to access the menu for your Cerbo from any computer. To use this, the Cerbo must be linked to the internet and the two-way communication option must be enabled.
- 5) **Notes:** Allows you to save notes for long term information.
- 6) **Photos:** Allows you to upload photos.
- 7) **Share:** Enables others to openly view your harvest information.
- 8) **Alarm Logs:** Shows any alarms that have occurred with a time stamp.
- 9) **Reporting:** Enables you to have data emailed to you.

VRM PORTAL

VRM Portal

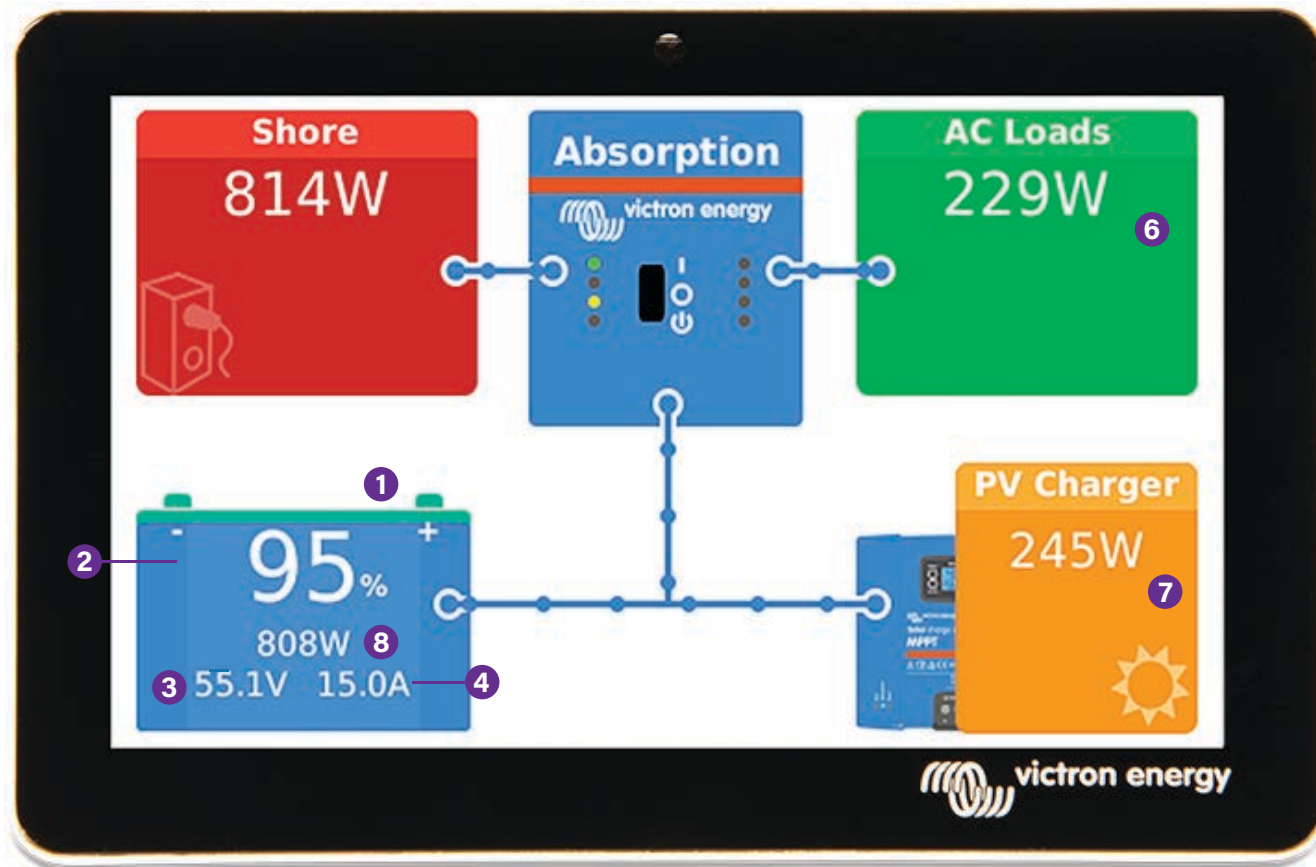

1) Battery Monitor: Shows SOC %, battery bank voltage as read by the SmartShunt, net current flowing into the battery bank, as well as a "Time to go" value.

2) SOC %: This allows you to gauge how much power is left in your battery bank. Think of it as a fuel gauge for your battery power.

3) Battery Voltage: This is going to be the most accurate place to read your battery voltage.

4) Net Current (In/Out): If this number is a negative (-0.1A) it indicates that you are removing energy from your battery bank. If this shows a positive number, it indicates putting energy into your battery bank.

5) AC Input/Generator: This is not used on the 1320i-L.

6) AC Loads: This is not used on the 1320i-L.

7) PV Charger: This shows the total power all of your monitored Solar Controllers are producing.

8) DC Power: This is a calculated value that typically shows how much power DC loads are using. For the 1320i-L the power to or from the Inverter is included in this calculation.

REMOTE CONSOLE

Understanding the Remote Console

Opening the Remote Console will bring up the system overview screen. This shows your battery information and total combined solar power. On the home screen there is also a moving graphic that represents where the power is coming from and going to in your system. The Cerbo-S GX has a lot of functionality that goes beyond the scope of this manual. For purposes of this manual, we will cover the basic items that a user needs to know to be able to utilize the off grid system. If you are interested in more detailed information about the capabilities of the Cerbo, please see the User Manual for the Cerbo-S GX (link on pg 22).

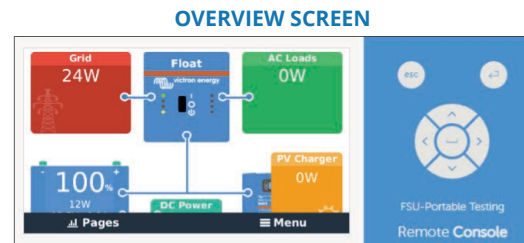

Remote Console Navigation

By selecting the space bar, the selection bar will momentarily pop up at the bottom of the screen. This is used to toggle between the Menu, and the home screen. Selecting "Pages" will return you to this home screen.

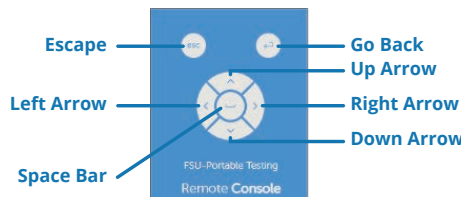
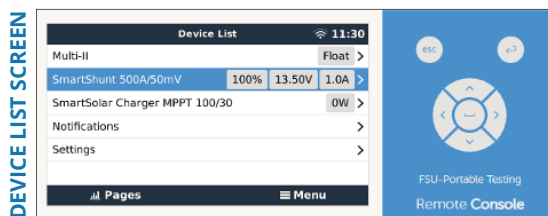

Selecting Menu will open to the main menu where you can select between the individual components hooked up to a Cerbo-S GX or you can go into settings of the Cerbo-S GX itself. Selecting any one of the components will allow you to view more detailed information about what that component is doing. Below the components is a 'Notifications' tab that will open a screen that will show the report of any error logged by the system. At the bottom of the list is the Settings tab.

Settings

Opening the Settings Menu will bring up a vast selection of functions (shown to the right). Many of these options are used with various other configurations of Victron Equipment. Not all apply to the SolarFlex system. Only items that pertain to the SolarFlex system will be discussed.

For more information on any of the settings, please refer to the Cerbo-S GX Owners Manual (link on pg 22).

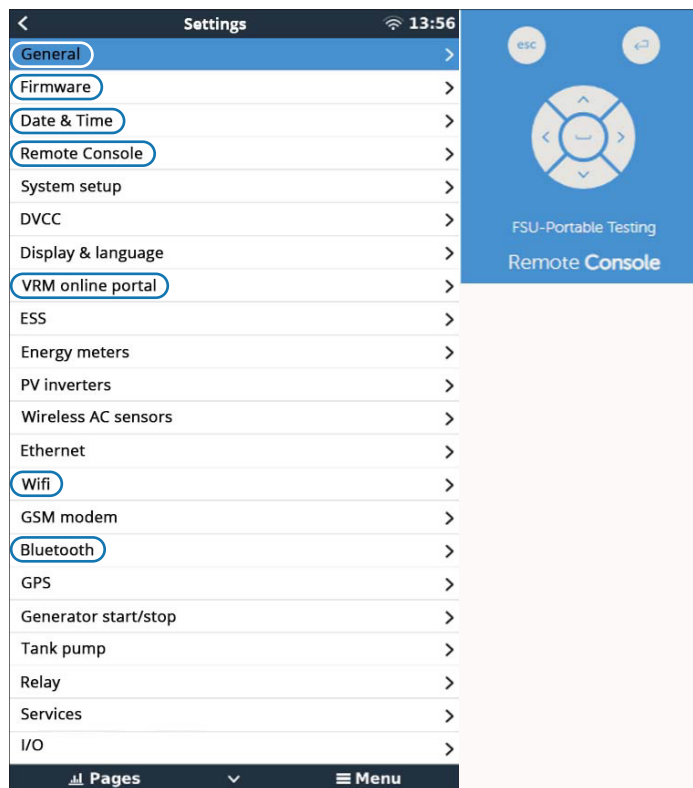

REMOTE CONSOLE CONTINUED

Understanding Settings

1) General

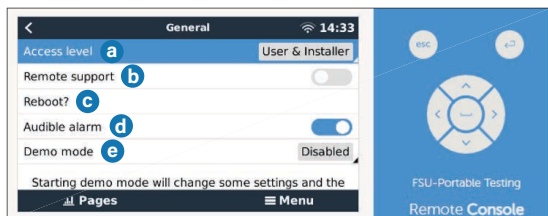

a. Access level: Allows for you to choose who can access your system.

b. Remote support: This option opens a support tunnel between secure servers at Victron and your Cerbo-S GX. This is not used and should remain off.

c. Reboot?: This will reboot your Cerbo-S GX in the event of certain settings changing or a communication glitch.

d. Audible alarm: Enable or disable an audible alarm when a fault occurs.

e. Demo mode: This should remain off.

2) Firmware

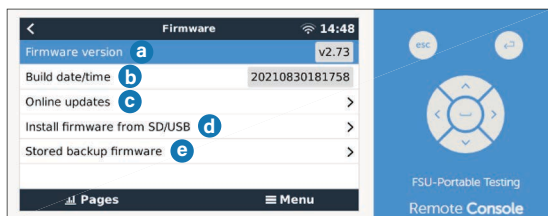

a. Firmware version: This is the firmware version the Cerbo GX-S is currently running.

b. Build date/time: This code allows Victron Engineers to trace firmware.

c. Online updates: Options to update firmware if internet is available.

d. Install firmware from SD/USB: Option to upload firmware downloaded to a USB drive or SD card from a PC.

e. Stored backup firmware: Stores previous version of firmware.

3) Date and Time

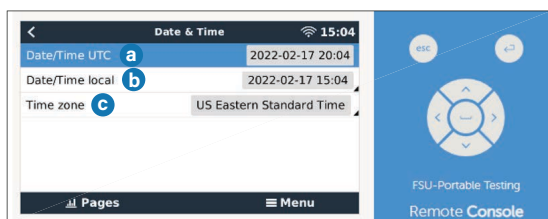

a. Date/Time UTC: This is the date and time in Coordinated Universal Time.

b. Date/Time local: This displays local time. You can also adjust the time and date manually here.

c. Time zone: This allows you to choose a time zone to set the local date and time by.

REMOTE CONSOLE CONTINUED

4) Remote Console

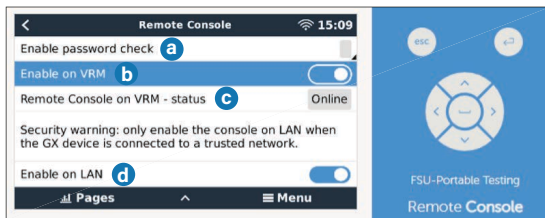

a. Disable password check: This allows connection to the Remote Console from the VRM or VictronConnect without an additional password.

a. Enable password check: Allows an additional password to be entered before remote console can be activated.

b. Enable on VRM: Allows remote console to be opened through the VRM portal.

c. Remote Console on VRM - status: Indicates if the Remote Console is currently connected through the VRM portal.

d. Enable on LAN: Enables a device to open the Remote Console if it is on the same network as the Cerbo-S GX.

5) VRM Online Portal

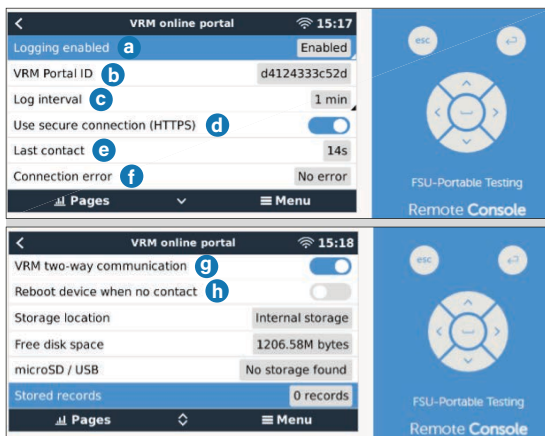

a. Logging enabled: Enable or disable data logging.

b. VRM Portal ID: Device identifier for VRM.

c. Log interval: How often data is logged.

d. Use secure connection (HTTPS): Only allow connection through secure channels.

e. Last contact: Time since last communication between VRM and Cerbo-S GX.

f. Connection error: Report of any communication error between VRM and Cerbo-S GX.

g. VRM two-way communication: Allows for data to be sent to the Cerbo from the VRM for Remote Console and other features.

h. Reboot device when no contact: If there is an error connecting to Wi-Fi, enabling this will automatically cause the Cerbo-S GX to re-boot in an attempt to clear the error.

6) Wi-Fi

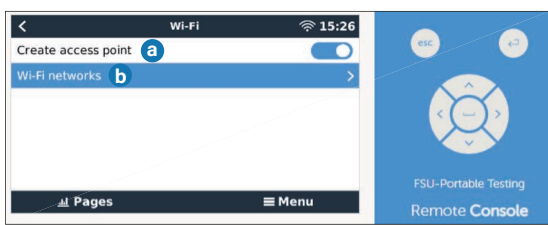

a. Create access point: This allows the Cerbo-S GX to enable the internal Wi-Fi option to provide a means of linking a smartphone or tablet if no other network is available.

b. Wi-Fi networks: This will allow you to connect to any available Wi-Fi network.

REMOTE CONSOLE CONTINUED

7) Bluetooth

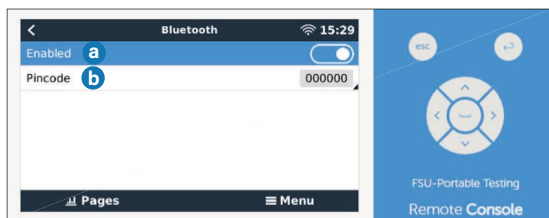

a. Enabled: Enable or disable Bluetooth communication from the Cerbo-S GX.

b. Pincode: Change the pincode needed to connect to the Cerbo-S GX via Bluetooth.

SmartShunt on Remote Console

Selecting the SmartShunt will allow you to view some of the more detailed information not seen on the home screen.

NOTE: All settings must be changed through the Bluetooth connection for the SmartShunt. The Cerbo-S GX will only display information from this device. For more information on settings for the SmartShunt, see pg 5.

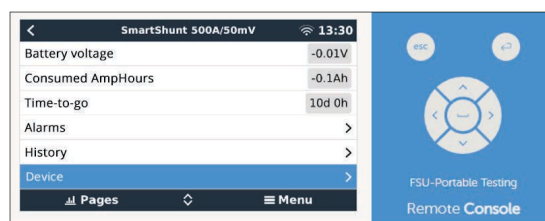

SmartSolar Controller on Remote Console

Each SmartSolar Controller will have its own item line in the main menu screen. By selecting one of the Controllers, the details screen will open to show valuable information regarding that specific Solar Controller.

NOTE: All settings must be changed through the Bluetooth connection for the SmartSolar Controllers. The Cerbo-S GX will only display information from this device. See pg 4 for more information SmartSolar Controller settings.

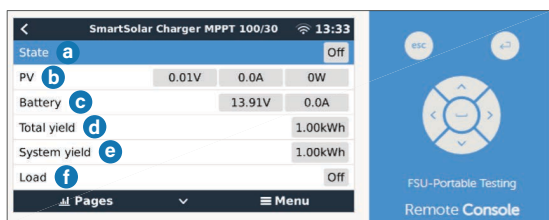

a) State: This shows if the Controller is on or off, and what charge stage it is in.

b) PV: This shows the voltage and current that the solar panels are providing to this Controller.

c) Battery: This shows the battery voltage as read at the output terminals of the Solar Controller and charging current the Controller is producing.

d) Total yield: Total amount of watts the system has produced with one Charger.

e) System Yyield: Total amount of watts the system has produced overall.

f) Load: This is not used on this system.

FAQs



Cerbo GX-S FAQs

How are DC loads measured?

This reading is actually a calculation done by the Cerbo, so it is possible for the accuracy to stray. The Cerbo uses information from the connected Victron equipment to determine where power is going. Any power that is not consumed or presented by a piece of Victron equipment that is connected to the Cerbo is accredited to DC loads.

What should my shore power limit be set to for my Inverter?

A good rule of thumb is to ALWAYS set the input current rating to match the breaker size on your shore outlet or portable generator.

My unit was connected to Wi-Fi but now I am showing a communication error?

Sometimes, communication can be lost when changing between mobile towers. Most often this is corrected by simply re-booting the Cerbo.

I can not access the remote portal from the VRM

This can happen when your system first connects to the internet after being offline for a period of time. This is because the system is unloading the logged data to the VRM. When observing the VRM portal from a computer, you should notice the "last connected" time getting smaller until it reaches "real-time". At this point you should be able to open the remote console.

If your system has not been offline, or if you are still having issues, follow these steps to verify settings and reboot the Cerbo.

- 1) Ensure you are connected to a Wi-Fi network with an internet connection.
- 2) Open the menu, select "Settings", then select "Remote Console".
 - a. Select "Disable Password".
 - b. Ensure "Enable on VRM" is selected (slider should be blue).
- 3) Back out of Remote Console, select "VRM Portal".
 - a. Ensure Logging is Enabled.
 - b. Ensure last contact is less than the log interval.
 - c. Ensure Connection error shows 'NO ERROR'.
 - d. Ensure VRM two-way communication is enabled.
- 4) Back out of Remote Console, select general, select "Reboot Device".

I can not access the remote portal from my smartphone or tablet.

In order to access the remote portal from a smartphone or tablet, you must either have your smartphone or tablet on the same Wi-Fi network as the Cerbo-S GX, or have the Cerbo-S GX connected to the VRM through an internet connection. See "Connecting to the Cerbo" section of manual (pg 11).

FAQs CONTINUED

Cerbo GX-S FAQs Continued

When and how should I update the firmware?

The Solar Controllers, battery monitor, and Cerbo-S GX all have Firmware that can be updated.

For SmartSolar Controllers and SmartShunt:

- 1) Open the VictronConnect app on a smartphone or tablet and connect to the device.
- 2) Select the Settings (⚙️) in the top right corner.
- 3) Select the Menu (☰) in the top right corner and open Product Info. If new firmware is available, you will be able to select 'Update' to download and install. This will need to be done for each Solar Controller and the SmartShunt separately.

For the Cerbo-S GX:

- 1) Open Remote Console.
- 2) Enter Menu, select Firmware.
- 3) Select Online Updates.
- 4) Select "Press to check for update" and follow prompts.

Can I change the name shown for my component?

Changing the name of the individual components is easiest through the Remote Console. To accomplish this:

- 1) Open the Remote Console.
- 2) Open the Menu, select the device.
- 3) At the bottom of the details menu for each device is an option named 'Device'.
- 4) Select this option, and here you can change the name displayed for your device.
- 5) Enter new name and select the green check mark at the bottom of the screen.



General FAQs

My DC loads shut down, but my battery monitor says I have plenty of SOC left.

Settings may need adjusted on your battery monitor. DFE recommended setting values are found on pg 6. You can also verify the SOC of the battery bank by using the *At Rest Voltage vs SOC Chart* on pg 21.

How do I expand my system?

Your system can be expanded through additional batteries and/or additional solar panels depending on floorplan. When adding batteries, you will need to keep the same chemistry and format as the original equipment. When adding solar panels, you will need to keep the panel voltage the same as your original equipment.

What steps can I take to maximize my run-time?

Conserve 12V power whenever possible.

Turn off any items not in use. Even small loads add up.

Take advantage of the sun.

While the sun is out, energy is essentially being replaced in the battery bank as it is being used. Running any heavy items during the day and minimizing what is ran at night can greatly improve your experience.

Turn off the heat pump fan when running the furnace.

If the fan for the air conditioner units are set to Auto, they will run the fan when the furnace is on to help circulate heat. Turning these off can help stretch out your battery bank charge.

TECH TIPS

BATTERIES

How Batteries are Rated

Amp Hours (Ah)- Unit of electric charge; 1A of current flowing for 1 hour.

Reserve Capacity (RC)- # of minutes a battery can maintain a useful voltage under a 25A discharge.

Conversion from Reserve Capacity to Ah: $Ah = ((Reserve\ Capacity \times 60) \times 25) / 3600$ or $Ah = Reserve\ Capacity / 2.4$.

Inverter prioritizes coach loads.

When on shore power and the electrical load of the coach is approaching the shore power limit set in the ME-RC. The Inverter has to make a decision about how to best use the power available. Items that are running in the coach are prioritized over battery charging. This means the first thing the Inverter is going to do as that limit is approached is slow down the charge rate. At a 100% charge rate, the Inverter is producing 120 amps of DC power for charging. This will require approximately 15 amps of AC power. If needed, the charge rate can be manually reduced in Setup Menu 05 of the ME-RC.

Load sharing and load shedding – when, why and how?

The 1320i-L has a lot of technology built in to it. The system has the ability to “boost” shore power with the Inverters load sharing capability as well as temporarily turn items off through the PCS to help ensure the breaker for the shore outlet does not trip. Understanding some basic points of information about these two devices will greatly improve your experience with the system.

- The Inverter shore power setting should always be set to match the breaker for the circuit the system is plugged in to. Having this set to match the available power, ensuring the ME-RC has the green INV LED on means if the draw starts to approach that threshold the Inverter will first reduce the Charger (all the way to 0 if needed), then begin load assisting if the draw is still near the threshold.

When using a smaller shore outlet, the PCS can be left at 30 amps, and the Inverter will load assist to produce the extra power when needed. This is providing the shore power limit is set correctly and the Inverter is in standby (green LED on while plugged in).

- When the Inverter is in load sharing mode, the batteries are not charging. This means it is possible to plug in to a small shore outlet and not be charging the batteries through the Inverter if larger loads are running.
- See PCS settings chart in appendix.

Charging – C rate explanation.

C rate is a term that can be found on any battery manufacturers charging recommendations. The C-rate of a battery is simply the highest amount of current that should be delivered to the battery during charging. The rating is usually listed as a number such as C / 5 or 0.2C. In either of these instances, the C stands for Capacity of the entire battery bank. DFE suggests a .5C charging rate. With two DFE GC3 batteries at 270 amp-hours each, the total capacity of a 1320i-L is 540 amp-hours (270 amp-hours per battery x 2 batteries in parallel = 540 amp-hours). This means up to 270 amps could be delivered to the bank through charging sources and still be within the manufacturers specification. Charging at a rate below the recommended C-rate is not harmful to the batteries, but exceeding the C-rate can shorten the over-all life span of the batteries.

APPENDIX: CHARTS

At Rest Voltage vs SOC Chart

To accurately use this chart to verify State of Charge readout from the SmartShunt, the batteries must be at rest. This means there should be no (or very little) current flowing in or out of the batteries. To use this chart, turn off as many items in the coach as possible. This includes turning off charging sources such as Solar Controllers temporarily. Ideally, there should be less than 20 amps of current flowing in or out of the batteries for 5 minutes, then compare the battery bank voltage to the listings on the chart. This will provide a fairly accurate estimate of SOC in a healthy battery bank.

VOLTAGE	CAPACITY
14.4V	100%
13.6V	100%
13.4V	99%
13.3V	90%
13.2V	70%
13.1V	40%
13.0V	30%
12.9V	20%
12.8V	17%
12.5V	14%
12.0V	9%
10.0V	0%

APPENDIX: LINKS

Future Solutions

Keystone Owners Manuals

<https://www.fsi-solutions.com/owners-manuals>

Keystone

Keystone Owners Manuals

<https://www.keystonerv.com>

Victron Energy

Cerbo-S GX User Manual

https://www.victronenergy.com/media/pg/Cerbo_GX/en/index-en.html

SmartSolar Controller User Manual

<https://www.victronenergy.com/upload/documents/Manual-SmartSolar-charge-controller-MPPT-100-30---100-50-EN-NL-FR-DE-ES-SE.pdf>

SmartShunt User Manual

<https://www.victronenergy.com/media/pg/SmartShunt/en/index-en.html>

VictronConnect User Manual

https://www.victronenergy.com/media/pg/VictronConnect_Manual/en/index-en.html

VRM Portal Documentation

https://www.victronenergy.com/live/vrm_portal:start

NOTES



Lined area for notes, consisting of 28 horizontal lines.